

T34...

Three-Phase Meter



The electricity meter type T34.. is suitable for measuring active energy for direct connection and connection via measuring transformers in three-phase three- or four-wire networks at balanced or unbalanced load.

The measuring and technical qualities of the meter T34.. comply with European Standard EN 60521 (IEC 521).

Their construction and mechanical dimensions comply with French standard UTE C 44000. Its construction enables adaptation to various requests in the measuring and technical qualities.

The accuracy class is 2. The meters connected via instrument transformers can be also class 1.

Meter case

The meter case is made of bakelite, highly resistant to creep current. Its degree of protection complies with IEC 529 - IP 53.

The meter cover is made of bakelite and is provided with a glass window through which a name plate, a register and a disc edge are visible. As option, it can be also made of transparent thermoplastic material. The cover is fastened to the base with two sealing screws, which enables sealing irrespective of the position of the terminal block cover.

A suspension hook and a holding stirrup, which are intended for mounting the meter, are fastened to the base.

Terminal block

The terminal block is fastened to the base with a pin. Terminals are embedded in a bakelite framework. For main circuits, the terminal holes have a diameter 8.5 mm, which is enough for connection of outer wires of 35 mm². Terminals for meters connected via instrument transformers have holes of 5.5 mm diameter. The auxiliary terminals for connection of external circuits have the holes of 3.2 mm diameter. The flashover and creep distances in the bakelite framework, between the metal parts of individual circuits on one hand, and terminals and outside contact parts on the other, are large enough to assure high breakdown strength.

The terminal block cover is made of solid, self-extinguishable, thermoplastic material or thermoset. It can be supplied in short, extended or middle version.

Measuring system

The meter employs three similar electromagnet elements, which are mounted on a robust die-cast frame. Two elements drive the lower disc and one the upper disc on which the brake magnet also operates.

The two-disc rotor is made of aluminium sheet, which is selected, for its conductivity and purity. The brake magnet is made of AlNiCo alloy, and sealed in a SiAl casting.

The rotor upper bearing consists of a steel needle guide with a sintered graphite pivot. No lubrication is necessary. The lower bearing can be two-cup, ball or magnetic type.

The voltage electromagnet of each element has a double magnetic circuit and the U-shape current electromagnet is used.

Electromagnetic sheet of a corresponding initial permeability in current cores assures specified error curves with respect to the load, either at small loads or overloads.

Register

The register can be single-rate or two-rate type. It consists of six or seven graduated drums. The rear register circumference is divided in to 100 sections.

A single-rate register can be provided with a standard digit drum with the size of numbers 4.7 x 2.3 mm, and with a larger digit drum with the size of numbers 6.9 x 3.65 mm. No lubrication of bearings is necessary.

The two-rate register is available only in a standard digit drum version. The tariff switchover is enabled by a changeover relay functioning via a differential gear. The changeover relay is a D.C. version and is supplied via the incorporated rectifier and the protective resistor.

Reverse running stop

A four-part stop is mounted beside the upper bearing and functions to the gear part of the upper bearing sleeve with a worm. The stop friction can be neglected. It does not influence in the meter accuracy and the start-up. If the impulse transmitter is built in the meter, a 24-part stop is mounted in the device. It can be incorporated on special request only.

Impulse output

Impulse transmitters (inductive type -5 and opto-electronic type -9) are built into three-phase reactive electricity meters. The impulse transmitters can be supplied with SO (DIN 43 864) or a relay impulse output. The electromagnetic compatibility complies with IEC 1036, Articles 5.5.2. to 5.5.5.

Impulse frequency is proportional to meter rotor speed as well as to electric energy consumption.

Transmission of pulses from the meter to the central unit is performed through special two-wire lines.

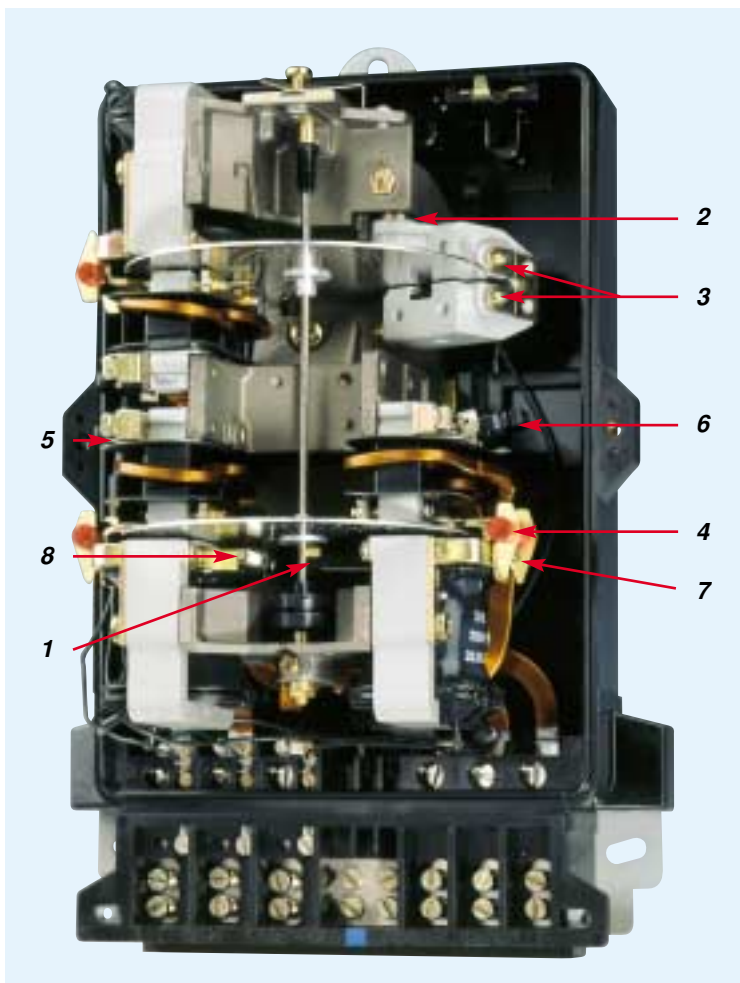

METER ADJUSTMENTS

- 1 – sensitivity adjustment
- 2 – coarse adjustment of number of revolutions
- 3 – fine adjustment of number of revolutions
- 4 – adjustment of small loads
- 5 – coarse phase adjustment
- 6 – fine phase adjustment
- 7 – balance of torques of driving elements
- 8 – reverse phase sequence adjustment

TECHNICAL DATA

Type	DIRECTLY CONNECTED METERS					METERS CONNECTED VIA INSTRUMENT TRANSFORMERS		
	T34B..	T34C..	T34F..	T34C..	T34E..	T34AT..	T34CT..	T34FT..
Rated voltage (V)	3 x 230 / 400							
Rated frequency (Hz)	50 or 60							
Rated secondary current of current transformer (A)						5	5	5
Basic current (A)	10	10	10	20	20	5	1,5	1
Max. current (A)	30	40	60	80	100	6	6	6
Thermal current (A)	36	48	72	96	115	7,2	7,2	7,2
Self consumption in voltage circuits at rated voltage (W)	3 x 1.10							
(VA)	3 x 5.20							
Self consumption in current circuits at basic current (W)	3 x 0.13	3 x 0.15	3 x 0.09	3 x 0.15	3 x 0.19	3 x 0.65	(at 5 A) 3 x 0.65	(at 5 A) 3 x 0.75
(VA)	3 x 0.15	3 x 0.16	3 x 0.11	3 x 0.16	3 x 0.20	3 x 0.81	3 x 0.81	3 x 1.07
Torque at basic load cca. (x10 ⁻⁴ Nm)	8,8	8,6	6,6	8,8	7.5	10	8.8	6.8
Rated number of revolutions at basic load (r.p.m.)	17,25	13,8	8,625	8,625	8,625	17,25	12,4	8,625
Meter constant (r./kWh)	150	120	75	37.5	37.5	300	750	750
Starting current at cos φ = 1	< 0.5 % I _b							
No-load running	Rotor does not run if the current circuit is open and if voltage varies from 80% to 110% U _r							
Weight of the rotor (g)	approx. 52 (with two-cup bearing), approx. 55 (with magnetic bearing)							
Weight of the meter (kg)	approx. 3.4 to 3.7							
Sinusoidal test voltage	2000 V rms							
Impulse voltage test	> 7kV (1,2/50 μs)							

Other rated voltages up to 500 V and currents (5/20, 5/30, 15/60, 30/90, 40/100, 5(3/6), 5(2.5/10 A)...) are also available on special request.

METER TYPE DESIGNATION

T 34 C T R D P 2 - 9

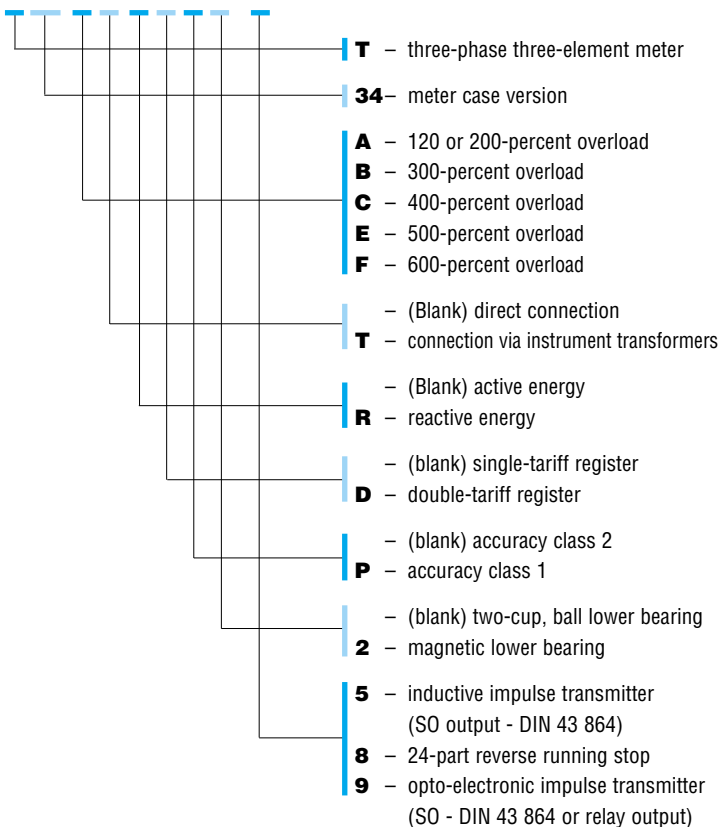

TYPICAL PERFORMANCE CHARACTERISTIC

Load curves

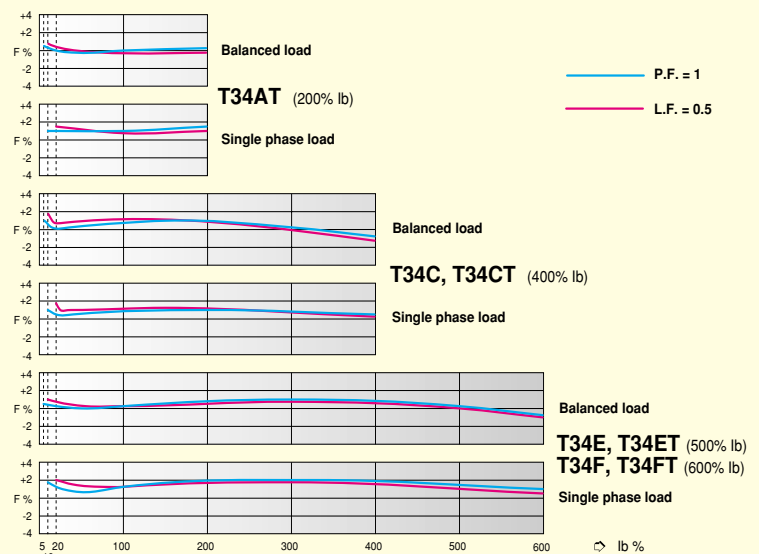

Error due to temperature variation

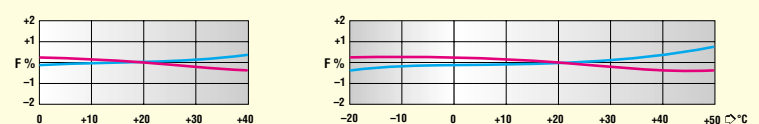

CONNECTION DIAGRAMS

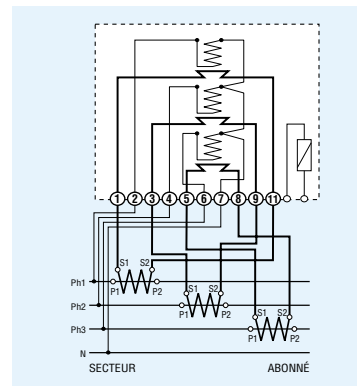
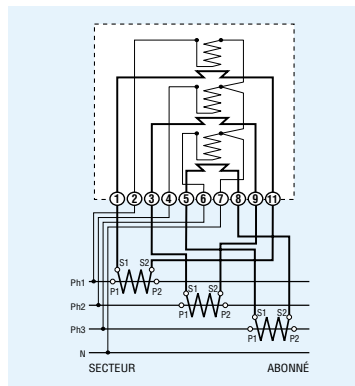
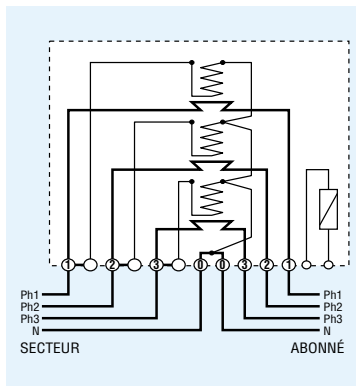
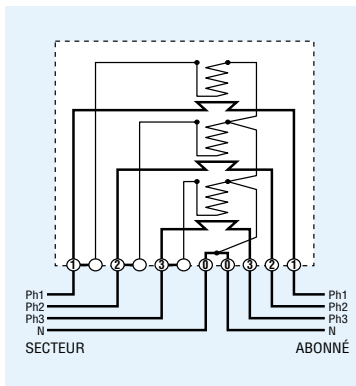

OVERALL AND FIXING DIMENSIONS

Direct connection

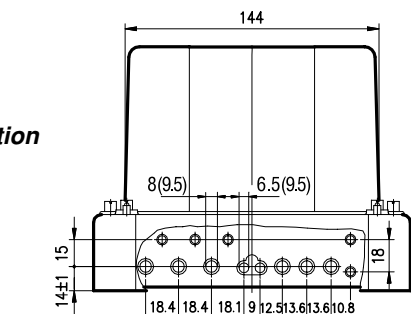

Connection via measuring transformers

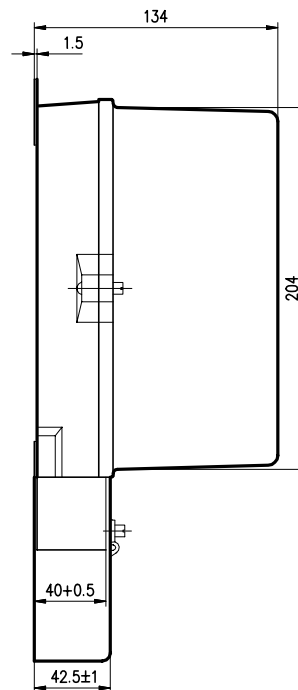
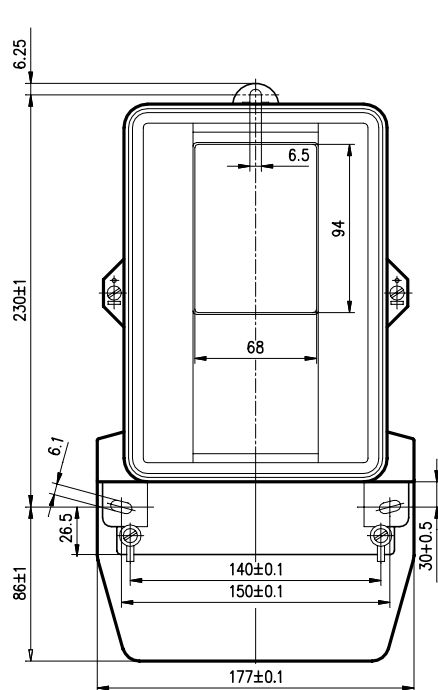
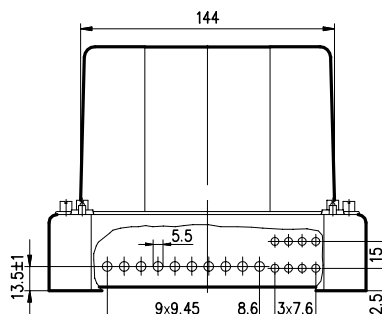

Owing to periodical improvements of our products the supplied products can differ in some details from the data stated in the prospectus material.