

EM1 (ME162i)

Single-phase meter

The EM1 (ME162i) single-phase electronic meter is intended for electric energy measurement and registration in single-phase two-wire networks in household. The meter has been designed in EU in compliance with the IEC 62052-11, IEC 62053-21 (IEC 61036) standards for kWh-meters, classes 2 and 1, as well as with IS 13779 and CBIP 88 with BIS certification. The meters are designed and manufactured in compliance with the ISO 9001 standard.



		Active energy and maximum demand
		One- or two-way energy flow direction, optionally always positive registration
		Single- or multi-rate registration
		Internal clock
		LCD
		Optical port
		Antifraud protection

- Internal clock
- Data display on LCD in no-power meter state (option)
- LCD backlight (option)
- Optical port for local meter programming and data downloading
- Energy measurement: one or two energy flow directions, optionally always positive registration
- Single wire measurement (option)
- External magnetic field detector (option at single-rate meters)

FUNCTIONAL AND TECHNICAL DATA

EM1 (ME162i) is a single-phase meter intended for residential users, for revenue measurement of active energy in single-phase two wire networks. The meter has two metering elements and fraud attempts indicators.

Two meter versions: single rate or multi-rate (maximum 4 rates)

Meter accuracy and calibration: Due to the long-term metering stability there is no need for recalibration in meter lifetime.

LED indicators:

imp/kWh - meter accuracy and operation

ETF – difference in energy measured with two metering elements

REV – Reversed energy flow direction

ON – Power ON

Data display:

7-segment LCD with seven digits + 1 digit for data identification code and 8 signal flags

LCD options:

LCD back-light illumination and data display in no-power meter state

Two modes of data display: Auto and manual data scroll

Additional data display: RMS voltage and current, instantaneous power

Communication: Optical port (IEC 62056 – 21): for local data downloading and meter programming. On request, billing data of previous months can be downloaded too.

Real time clock:

– 32 kHz quartz oscillator

– The real time clock generates: a tariff program, demand period, automatic meter billing reset, season changeover, transition to day light saving period and vice-versa.

Meter case: Polycarbonate, self-extinguishing. Transparent meter and terminal covers. Terminal cover with a hinge. Handle for meter carrying.

Protection against dust and water: IP 53.

OVERALL DIMENSIONS (mm)

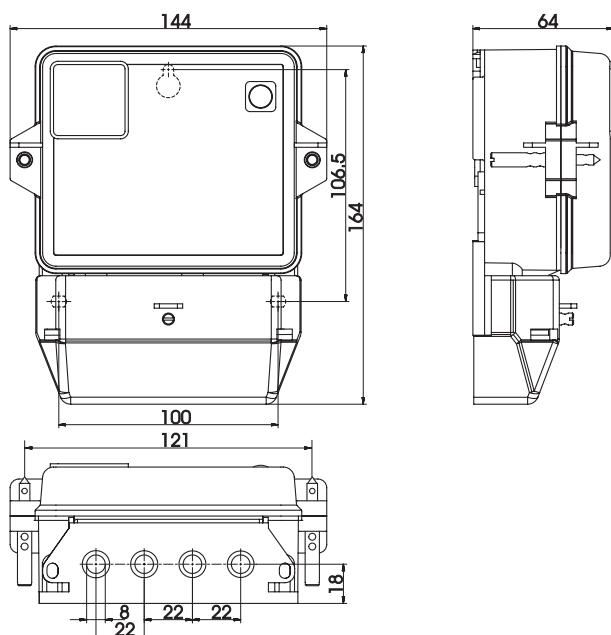

Accuracy class	.2 or 1
Basic current I _b	.2.5, 5 or 10 A
Max. current I _{max}	.10, 20, 30 A
Min. current	.0.05 I _b
Starting current	.0.004 I _b
Reference voltage U _r	.120, 220, 230, 240 V
Voltage range	.0.8 U _n ... 1.15 U _n
Reference frequency	.50 or 60 Hz
Meter constant	.3,200 imp/kWh
Clock accuracy (25°C)	.≤ 6 ppm or ≤ ± 3 min/year
RTC control	.32 kHz crystal
RTC operation reserve	.5 years (Li-battery)
Optical port	.IEC 62056-21 (IEC 61107)
Operating temperature range	-.25°C ... +60°C
Extended temp. range	-.40°C ... +70°C
Storing temperature	-.40°C ... +85°C
Voltage circuit burden	.<1.5 W / 8 VA
Current circuit burden	.<0.16 VA
Short-circuit current	.30 I _{max}
Dielectric strength	.4 kV, 50 Hz, 1 min
Impulse voltage	.8 kV, 1.2/50 μs
Fast transients (burst)	.6 kV (IEC 61000-4-4)
Dimensions (h x w x d)	.164 x 144 x 64 mm
Mass	.Approx. 0.350 kg

CONNECTION DIAGRAM

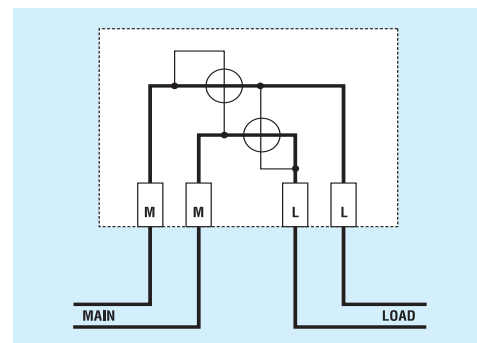

TYPE DESIGNATION FOR ORDERING

EM1-D3A41-M3KO (ME162i-D3A41-M3KO)

(ME162i)

EM1 – Electronic single-phase meter with two metering elements and RTC

D3 – Symmetrical terminal block for direct connection

A4 – Active energy measurement, accuracy class 1

A5 – Active energy measurement, accuracy class 2

1 – Energy measurement in one direction

2 – Energy measurement in two directions

4 – Absolute energy measurement

M – Real-time clock

3 – Li-battery for RTC back-up

KO – Optical port IEC 62056-21 (IEC 61107)

Owing to periodical improvements of our products the supplied products can differ in some details from the data stated in the prospectus material.

Iskraemeco, Energy Measurement and Management
 4000 Kranj, Savska loka 4, Slovenia
 Telephone: (+386 4) 206 40 00, Telefax: (+386 4) 206 43 76,
<http://www.iskraemeco.si>, e-mail: info@iskraemeco.si
 Published by Iskraemeco. Data subject to alteration without notice.